

User's Manual

Model DX-330

Digital Vector Magnetometer



Dexing Magnet Tech. Co., Ltd

Add:No.300-402 RD West Jinshan, Huli Dist.,Xaimen China

Zip code:361015

Tell:+86-592-5237772

Fax:+86-592-5237901

Webpage:www.magnetic-instrument.com

Email address:sales@magnetsource.cn

Methods and apparatus disclosed and described herein have been developed solely on company funds of Dexing Magnet Tech.Co.,Ltd No government or other contractual support or relationship whatsoever has existed which in any way affects or mitigates proprietary rights of Dexing Magnet Tech.Co.,Ltd in these developments. Dexing Magnet Tech.Co.,Ltd reserves the right to add, improve, modify, or withdraw functions, design modifications, or products at any time without notice. Dexing Magnet Tech.Co.,Ltd shall not be liable for errors contained herein or for incidental or consequential damages in connection with furnishing, performance, or use of this material.

Add: No.300-402, Rd. West Jinshan, Huli Dist. Xiamen,China Zip code: 361015

Tel: 86-592-5237772 Fax: 86-592-5237901

Email: sales@magnetsource.com.cn



Dexing Magnet Tech. Co., Ltd

LIMITED WARRANTY STATEMENT

Dexing warrants that this Dexing product (the "Product") will be free from defects in materials and workmanship for the Warranty Period specified as 12 months from the date of delivery of the Product. If Dexing receives notice of any such defects during the Warranty Period and the Product is shipped freight prepaid, Dexing will, at its option, either repair or replace the Product if it is so defective without charge to the owner for parts, service labor or associated customary return shipping cost. Replacement or repaired parts will be warranted for only the unexpired portion of the original warranty. This limited warranty does not apply to defects in the Product resulting from improper or inadequate maintenance, repair or calibration.

Dexing Magnet Tech.Co.,Ltdcan provide maintenance services to the product out of the warranty period with charge to the owner for parts, service labor or associated customary return shipping cost. Replacement or repaired parts will be warranted for 90 days.

In any circumstances , Dexing Magnet Tech.Co.,Ltd has the right to refuse to provide any form of warranty, repair or maintenance servicesif this product has been unauthorized modified or misused.

COPYRIGHT STATEMENT

Dexing Magnet Tech.Co.,Ltd hold the right of the manual. All rights reserved. Reproduction, reshipping, or spread is prohibited without the prior express written permission of Dexing Corporation.



TABLE OF CONTENTS

CHAPTER 1 CHAPTER 1 INTRODUCTION	6
1.0 GENERAL	6
1.1 PRODUCT DESCRIPTION	7
1.2 SPECIFICATIONS	8
1.2.1 General Measurement.....	8
1.2.2 DC Measurement	8
1.2.3 Front Panel.....	8
1.2.4 Interfaces functions	9
1.2.5 General.....	9
1.2.6 Ordering Information.....	9
1.3 SAFETY SUMMARY	10
1.4 SAFETY SYMBOLS	11
CHAPTER 2 INSTALLATION	12
2.0 GENERAL	12
2.1 INSPECTION AND UNPACKING	12
2.2 REPACKAGING FOR SHIPMENT.....	12
2.3 Line Voltage and Fuse Verification	13
2.4 PROBE INPUT CONNECTION	14
2.5 ANALOG OUTPUT MONITORING	14
2.6 RS-232C CONNECTION	15
2.7 INITIAL SETUP AND SYSTEM CHECKOUT PROCEDURE	15
CHAPTER 3 OPERATION	17
3.0 GENERAL	17
3.1 DEFINITION OF FRONT PANEL CONTROLS 17	
3.1.1 Front Panel Keypad.....	17
3.1.2 Front Panel Display.....	18
3.1.3 General Keypad Operation	19



Dexing Magnet Tech. Co., Ltd

3.2 Units	19
3.3 RANGE	19
3.4 Save	19
3.5 Menu (single direction movement)	19
3.6 Max/Min	20
3.7 Zero.	20
3.8 Enter	20
3.9 Relative	20
3.10 Reset	20
3.11 ▼▲	20
3.12 Menu function-describing	21
3.12.1 Time setting	21
3.12.2 Cal check.....	21
3.12.3 Threshold value setting.....	21
3.12.4 Brightness Settings.....	22
3.12.5 Save setting.....	22
3.12.6 UART baud rate select and send data.	22
3.13 PROBE CONSIDERATIONS	22
3.13.1 Changing Probes.....	22
3.13.2 Probe Handling.....	23
3.13.3 Probe Operation	23
3.13.4 Probe Accuracy Considerations.....	23
CHAPTER 4 REMOTE OPERATION.....	25
4.0 GENERAL.....	25
4.1 SERIAL INTERFACE OVERVIEW.....	25
4.1.1 Physical Connection.....	25
4.1.2 Hardware Support.....	26
4.1.3 Character Format	26



Dexing Magnet Tech. Co., Ltd

4.1.4 Trouble Shooting.....	27
4.1.5 Computer Control Command	27
4.1.6 Connect to Software.....	29
CHAPTER 5 ACCESSORIES.....	33
5.0 GENERAL	33
5.1 ACCESSORIES.....	33
5.2 CABLE.....	33
5.3 Rittal.....	34
CHAPTER 6 OPTIONAL PARTS.....	35
6.0 general.....	35
6.1 Dexing Magnet Tech.Co.,Ltd Zero gauss chamber.....	35
6.2 Dexing Magnet Tech.Co.,Ltd Gauss Meter Professional mapping software	35
CHAPTER 7 SERVICE.....	40
7.0 GENERAL.....	40
7.1 GENERAL MAINTENANCE PRECAUTIONS	40
7.2 ELECTROSTATIC DISCHARGE.....	41
7.2.1 Identification of Electrostatic Discharge Sensitive Components.....	41
7.2.2 Handling Electrostatic Discharge Sensitive Components.....	41
7.3 FUSE REPLACEMENT.....	42
7.4 REAR PANEL CONNECTOR DEFINITIONS.....	42
7.5 Serial Interface Cable Wiring.....	44
APPENDIX A UNITS FOR MAGNETIC PROPERTIES	45
APPENDIX B GLOSSARY OF TERMINOLOGY.....	39



CHAPTER 1 INTRODUCTION

1.0 GENERAL

This chapter provides an introduction to the Dexing Model 330 flux-gate magnetometer. The Model DX-330 was designed and manufactured in Beijing of China by Dexing Magnet Tech.Co.,Ltd The Model DX-330 is an extremely highly accurate and high resolution intellectualized flux-gate magnetometer that is well suited for field work. It features:

- Resolution to 5¼ Digits VGA
- Basic accuracy of measurement: readings $\times \pm 0.5\%$ \pm range $\times \pm 0.05\%$
- A maximum / minimum value/ peak values/ gorge value hold / screen locked
- Basic resolution: 1nT
- Data storage (Auto / Manual) / stored data read
- Auto-zero, automatic, manual selecting range
- Probe auto calibration/ auto memory operation mode
- RS232 Serial Interface/ USB data communication/ analog signal interface
- Display unit can be nT,mG
- Zero setting/ Relative measurement mode
- Measurement graphical display, Communication baud rate adjustable
- Threshold settings and alarm
- Date, time settings/ brightness display
- Dozens of basic Optional Probe

If you have just received your new Model DX-330, please proceed to Chapter 2 and become familiar with the installation instructions. Complete and detailed instrument and probe operational information is contained in Chapter 3. Chapter 4 contains details on remote operation using the Serial Interface. Details on accessories and probes are provided in Chapter 5. Optional parts are contained in Chapter 6. maintenance is contained in Chapter 7. Appendix A is a glossary of terminology. Appendix B provides units for magnetic properties.

It is welcome to annotate this manual. Though we have done our best to maintain the correctness of the manual, there is a possibility to have errors. When you report a specific error, please give out a brief description dedicate the Chapter, illustration, table, Paragraph. We will appreciate that you send this annotateion to Dexing Magnet Tech.Co.,Ltd



Figure 1-1 DX-330 3D Flux-gate Magnetometer Front Panel

1.1 PRODUCT DESCRIPTION

The Digital Model DX-330 3D Flux-gate Magnetometer is the most advanced in the world, using the new technology of magnetic field measurement. Its panel is easy to operation, and it has a good human-computer interaction interface. Using large size VGA screen, you can easily display all the required information, and choose whether to display. All options can be done by the operating button panel. VGA can display different measurements on each channel at the same time, such as 3D magnetic field density, temperature, maximum value, minimum value, date and time. DX-330 can store the data and output the real-time data in digital or analog. DX-330 can be equipped with three axis flux-gate sensor.

High accuracy, high resolution

Combined with high accuracy digital instrument and high accuracy digital hall probe, DX-330 3D Flux-gate Magnetometer makes its accuracy up to readings $\times\pm 0.50\%$ \pm range $\times\pm 0.05\%$, basic resolution to 1nT, and then it comes up to the top level of the field measuring world.

High Intelligence, multifunction

DX-330 3D Flux-gate Magnetometer has multifunctions such as measuring the DC and AC Magnetic Field, max /min / peak/valley values hold / locking layout, data storage (manual /automatic) / data reading, excellent graphics and self-test pattern display function, probe autocorrection, automatically memorize the operation mode, auto-zero, automatic / manual adjust range, threshold setting and alarm, show temperature and time ,brightness self-setting, and display unit optional: nT, mG and so on..

Automation

DX-330 3D Flux-gate Magnetometer has a variety of interface features that are compatible with automated test configurations. The RS-232C Serial Interface can perform nearly every function of the instrument front panel. Two analog voltages and an alarm relay facilitate automation without a computer. At the same time, DX-330's monitoring analog output cases to provide supplementary automation capabilities and an optional remote control system without the use of PC.



Conformity

The DX-330 has strong stability and conformity. The conformity can reach 0.3% (stable magnetic field).

Probe

The DX-330 is delivered with Dexing (德兴) all serial three-dimensional flux-gate probe. Probes are factory calibrated for accuracy and interchangeability. Calibration data is loaded into a PROM located in the probe connector so that it does not have to be entered by the user.

1.2 SPECIFICATIONS

1.2.1 General Measurement

Number of Input: 3
Update Rate: 3 readings per second on display
Probe Compatibility: Dexing series of probes
Probe Features: linearity correction, auto probe zero
Connector: 15 pin D style(DB15)

1.2.2 DC Measurement

DC Accuracy: $\pm 0.50\%$ of reading $\pm 0.05\%$ of range
DC Range: 0-100000nT
DC Temp. Coefficient: ± 0.1 of reading / $^{\circ}\text{C}$
DC measurement Resolution: 0.01mG (1nT)

CAUTION: Vertical probe X flag is the X direction of the magnetic field, and vertical probe Y flag is the Y direction of the magnetic field, and vertical probe Z flag is the Z direction of the magnetic field.

1.2.3 Front Panel

Display Type: 480 * 320 Color LCD screen
Display Units: mG, nT
Keypad: 14 key membrane
Front Panel Features: Intuitive operation, display prompts



```

                AUTO  DC
X: -087668      nT
Y: +033354      nT
Z: -070821      nT
2012/10/21  10:33  17.3 °C
    
```

1.2.4 Interfaces functions

RS-232C Capabilities:

Baud: 19200, 57600, 115200

Connector: 9 pin D style(DB), DCE configuration(direct connected to PC)

Output stage: real-time analog voltage output

Output range: $\pm 3V$

Accuracy: related to the probe

Load capacity: the minimum load resistance is 1k (short circuit protection)

1.2.5 General

Ambient Temperature: 15 – 35 °C at rated accuracy. 0 °C – 40 °C with reduced accuracy.

Power Requirement: 220 VAC (+5%, -10%), 50 or 60 Hz, 20 watts

Size: 520mm W × 140 mm H × 387 mm D, half rack (12.5 × 4.3 × 11.3 inches)

Weight: 6 kilograms

1.2.6 Ordering Information

Part Number Description

Instrument

DX-330

The Digital Model DX-330 3D Flux-gate Magnetometer

Accessories Included:

Model MCHD801F

regular digital three-dimensional flux-gate probe with range of
0-100000nT one

220-10

220VAC power wire one

Man-330

model DX-330 3D Flux-gate Magnetometer User's

Add: No.300-402, Rd. West Jinshan, Huli Dist. Xiamen,China Zip code: 361015

Tel: 86-592-5237772 Fax: 86-592-5237901

Email: sales@magnetsource.com.cn



Dexing Magnet Tech. Co., Ltd

	Manual	one
RS232-DCE9	9 pin RS232 direct Communication Cable	one
Dexing	Flux-gate Magnetometer Data communication software	one
Calibration Certification		one
Warranty		one
Accessories Optional:		
RS232-USB	RS232 TO USB 2.0 interface transfer or IEEE485	one

1.3 SAFETY SUMMARY

Observe the following general safety precautions during all phases of operation, service, and repair of this instrument. Failure to comply with these precautions or with specific warnings elsewhere in this manual violates safety standards of design, manufacture, and intended use of the instrument. Dexing Magnet Tech.Co.,Ltd assumes no liability for customer failure to comply with these requirements.

Please read carefully the following general safety precautions during all phases of operation, service, and repair of this instrument. The instrument should be operated by Professional who are familiar with **shock hazard** and can deal with the damage made by **shock hazard**. When the instrument is in function of all phases of measuring or control, any other circuit may carry with danger voltage what means that r.m.s values of AC voltage is greater than 30V, and that peak voltage is greater than 42.4V, or that AC voltage is greater than 60V, and may cause the **shock hazard** accident. The danger voltage can appear on the box of DX-330, the cable plug, the cable receptacle, sensor metal shell, measuring fixture, or any place of any instruments that connect to DX-330. The Model CH-1500 protects the operator and surrounding area from electric shock or burn, mechanical hazards, excessive temperature, and spread of fire from the instrument. Environmental conditions outside of the conditions below may pose a hazard to the operator and surrounding area.

- Temperature: 5 – 40 °C.
- Maximum Relative Humidity: 80% for temperatures up to 31 °C decreasing linearly to 50% at 40 °C.
- Power supply voltage fluctuations not to exceed $\pm 10\%$ of the nominal voltage.

Ground The Instrument

To minimize shock hazard, connect instrument chassis and cabinet to an electrical ground. The instrument is equipped with a three-conductor AC power cable; either plug it into an approved three-contact outlet or use a three-contact adapter with the grounding wire (green) firmly connected to a ground (safety ground) at the power outlet. The power jack and mating plug of the power cable meet safety standards of the state.

Do Not Operate In An Explosive Atmosphere

Do not operate the instrument in the presence of flammable gases or fumes. It is a safety hazard.

Keep Away From Live Circuits Inside the Instrument

Operating personnel must not remove instrument covers. Refer component replacement and internal adjustments to qualified maintenance personnel. Do not replace components with power cable connected. To avoid injuries, always disconnect power and discharge circuits before touching them.














Do Not Substitute Parts Or Modify Instrument

Because of the danger of introducing additional hazards, do not install substitute parts or perform any unauthorized modification to the instrument. Return the instrument to an authorized Dexing Magnet Tech.Co.,Ltd representative for service and repair to ensure that safety features are maintained.

Do Not Place Conductive Probes Against Exposed Electrical Circuits

Some Gauss/Tesla meter probes are equipped with conductive sheaths. Keep these probes away from live electrical circuits.

1.4 SAFETY SYMBOLS

	Direct current (power line).		Equipment protected throughout by double insulation or reinforced insulation (equivalent to Class II of IEC 536 - see Annex H).
	Alternating current (power line).		Caution: High voltages; danger of electric shock. Background color: Yellow; Symbol and outline: Black.
	Alternating or direct current (power line).		Caution or Warning - See instrument documentation. Background color: Yellow; Symbol and outline: Black.
	Three-phase alternating current (power line).		Fuse.
	Earth (ground) terminal.		
	Protective conductor terminal.		
	Frame or chassis terminal.		
	On (supply).		
	Off (supply).		



CHAPTER 2 INSTALLATION

2.0 GENERAL

This chapter provides general installation instructions for the digital model DX-330 3D flux-gate magnetometer. Inspection and unpacking instructions are provided in Paragraph 2.1. Repackaging for shipment instructions are provided in Paragraph 2.2. An definition of rear panel controls is provided in Paragraph 2.3-2.6. Finally, an initial setup and system checkout procedure is provided in Paragraph 2.7.

2.1 INSPECTION AND UNPACKING

Inspect shipping containers for external damage, and damage (apparent or concealed) or partial loss of shipment. If damage or loss is apparent, please notify the shipping agent immediately.

Open the shipping containers. A packing list is included with the system to simplify checking that the instrument, probe(s), accessories, and manual were received. Please use the packing list and the spaces provided to check off each item as the instrument is unpacked. Inspect for damage. Be sure to inventory all components supplied before discarding any shipping materials. If there is damage to the instrument in transit, be sure to file proper claims promptly with the carrier and insurance company. Please advise Dexing Electronic devices of such filings. In case of parts or accessory shortages, advise Dexing immediately. Dexing cannot be responsible for any missing parts unless notified within 10 days of shipment.

2.2 REPACKAGING FOR SHIPMENT

If it is necessary to return the Model 330, probe(s), or accessories for repair or replacement, the original packing material should be retained for reshipment. please packet the instrument with protecting bag, and use the original packing filler to protect, repackage them in original packing box, and tied up with nylon belts, and paste the shipping label and "FRAGILE" label.

Because of their fragility, Dexing probes are shipped in special cardboard and foam boxes. These boxes should be retained for storage of probes while the Gauss/Tesla meter is not in use. The same box can be used to return probes to Dexing for recalibration or repair.

This paragraph provides a description of the Model 330 rear panel connections. The rear panel consists of: 1) the line input assembly, safe subassembly, 2) Serial I/O Connector,3) monitor analog output connector ,4)Probe Input Connector. Please read paragraph2.3-2.6 then proceed to Paragraph 2.7 for the initial setup and system checkout procedure. Rear panel connector pin-out details are provided in Chapter 6 – Service.

CAUTION: Verify AC Line Voltage shown in the fuse holder window is appropriate for the intended AC power

input. Also remove and verify the proper fuse is installed before plugging in and turning on the instrument.

CAUTION: Always turn off the instrument before making any rear panel connections. This is especially critical when making probe to instrument connections.

2.3 Line Voltage and Fuse Verification

To verify proper line voltage selection look at the indicator in the window on the fuse drawer of the line input assembly. Line voltage should be in the range shown in the specifications listed on the back of the instrument. See Figure 2-2. The Model 330 includes a three-conductor power cord. Line voltage is present across the outer two conductors. The center conductor is a safety ground and connects to the instrument metal chassis. For safety, plug the cord into a properly grounded three-pronged receptacle or adapter that meets the safe standard of the state.

The fuse must be removed to verify its value, refer to the procedure. Use slow-blow fuses of the value specified on back of the instrument.

The power switch turns the instrument On and Off and is located in the line input assembly on the instrument rear. When I is raised, the instrument is On. When O is raised, the instrument is Off.

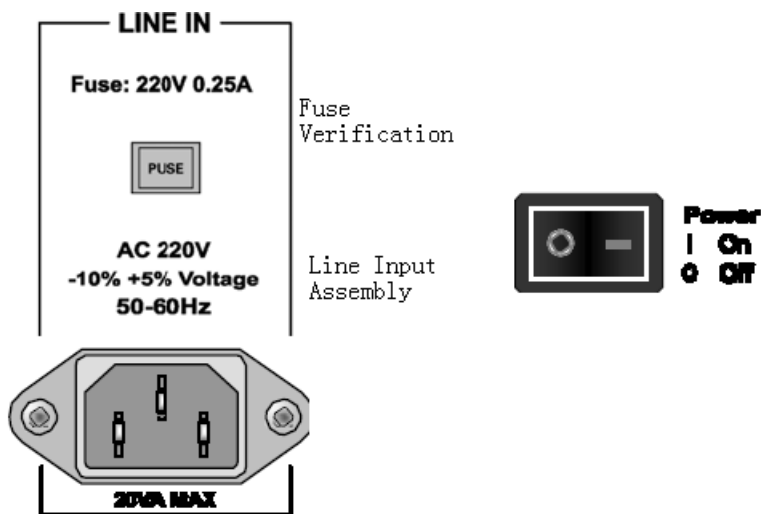


Figure 2-2 A:Line Input Assembly and Fuse Verification(Left rear panel)
B:Power Switch (low left of the front panel)

2.4 PROBE INPUT CONNECTION

WARNING: Some probes used with the flux-gate magnetometer have conductive parts. Never probe near exposed live voltage. Personal injury and damage to the instrument may result.

CAUTION: Always turn off the instrument before making any rear panel Probe Input connections.

Dexing instrument should always go with the Dexing serial flux-gate probes. Never use any other kind of probes in order of avoiding instrument and probe damage. Dexing probes plug into the 15 pin D-style connector on the Model 330 rear panel. Turn the instrument off and plug the power cord out of the power input receptacle before attaching a probe. Avoiding to bend the contact pin, straightly and gently insert the probe input connector into the rear panel connector. For reliability, please use thumbscrews attached to the probe connector to tighten connector to unit on the rear panel. Thumbscrews can ensure cable safe and avoid disturbance.

When power is turned on, the instrument reads parameters from probe memory. The probe is ready to use. No parameters need to be entered into the Model 330. However, the Zero Probe function should be performed the first time a probe is used with the instrument and periodically during use.

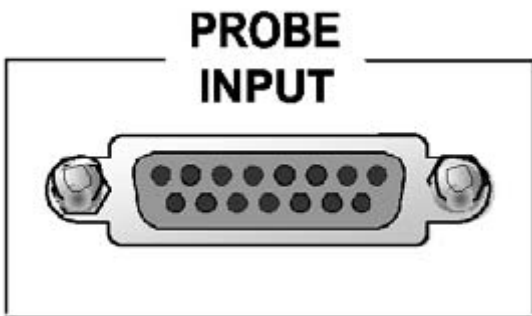


Figure 2-3 PROBE INPUT Connector

2.5 ANALOG OUTPUT MONITORING

The digital model DX-330 3D flux-gate magnetometer uses BNC socket to provide analog output. The signal is located in the center conductor, and the shell is grounding. The analog output is monitored is the analog signal which is proportional to the magnetic field strength. Refer to chapter 3 for more operation of analog output monitoring.



Figure 2-4 BNC connector

2.6 RS-232C CONNECTION

The Model 330 has a 9 pin D-Subminiature plug on the rear panel for serial communication, and DCE configuration. It can connect to PC by 9 pin serial port through the direct cable, or by 25 pin serial port through the 9 pin to 25 pin cable. Find more information about Serial cable connection in chapter 7.

DX-330 has as optional accessory RS232 to USB 2.0 interface transfer that will transfer the 1500 serial port to USB, along with it the windows driver in the installation disk. For more information please see in chapter 5.

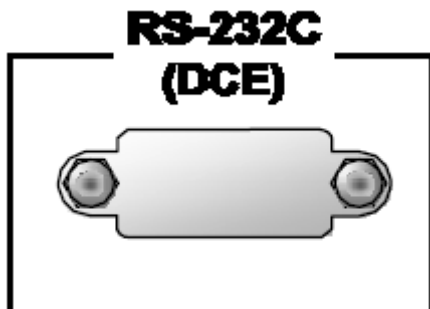


Figure 2-5 RS-232 (DCE) Connector

2.7 INITIAL SETUP AND SYSTEM CHECKOUT PROCEDURE

The following procedure is an initial instrument setup and checkout procedure. The intent of this procedure is to verify basic operation of the unit before beginning use for measurements.

1. Ensure the power switch is in the off (O) position.

CAUTION: The probe must be connected to the rear of the unit before applying power to the flux-gate magnetometer. Damage to the probe may occur if connected with power on.

2. Plug in the probe connector to 15 pin PROBE INPUT. Use thumbscrews to tighten connector to unit.

3. Ensure any other rear panel connections (SERIAL I/O or ANALOG OUTPUTS) are connected before applying power to the unit.

4. Check window in fuse drawer for proper voltage setting.

5. Plug line cord into receptacle. Plug the other end of the line cord into an approved three-contact outlet or use a three-contact adapter with the grounding wire (green) firmly connected to a ground (safety ground) at the power outlet.



Dexing Magnet Tech. Co., Ltd

NOTE: For best results, the instrument and probe should warm up for at least 15 minutes before zeroing the probe, and at least 30 minutes for rated accuracy.

6. DX-330 provides zeroing mode (x, y, z)

Zeroing mode: DX-330 has been calibrated before leaving factory,

- 1) Magnetic shielding tube: Such as testing the nT levels of weak magnetic signal, suggest that place the probe in the center of magnetic shielding tube, and press the reset button to calibrate zero point.
- 2) Elimination of geomagnetic model: place probe in horizontal to be perpendicular to magnetic field with relative measurement mode. Then press X, Y, Z key on the front panel to correct zero point.

Never move the probe in the process of check-zero which followed by a return to the normal display. After correcting the zero point, relative value measurement can be performed. It will recover if restarted.

CHAPTER 3 OPERATION

3.0 GENERAL

This chapter describes model DX-330 3D flux-gate magnetometer operation. The front panel controls are described in Paragraph 3.1. Paragraphs 3.2 thru 3.11 describe the various front panel functions in detail. Finally, Paragraph 3.12 provides probe handling considerations.

3.1 DEFINITION OF FRONT PANEL CONTROLS

This paragraph provides a description of the front panel controls on the Model 330.



Figure 3-1 DX-330 3D flux-gate magnetometer's Front Panel

3.1.1 Front Panel Keypad

The keys on the front panel are defined as follows. Note the following are abbreviated descriptions of each key. A more detailed description of each function is provided in subsequent paragraphs.

Hold: Keep the test value

Units: Change display units from mG to nT.

Range: Automatic range

Save: used to store the data through the set way

▲▼ : Toggle between various settings shown in the display and increments / decrements a numerical display



Dexing Magnet Tech. Co., Ltd

Menu: Use to open the menu

Max/Min: Turn the peak reading measuring feature on and off. Capture and display the highest or lowest field readings.

Zero: Use to zero or null effects of ambient low level fields from the probe

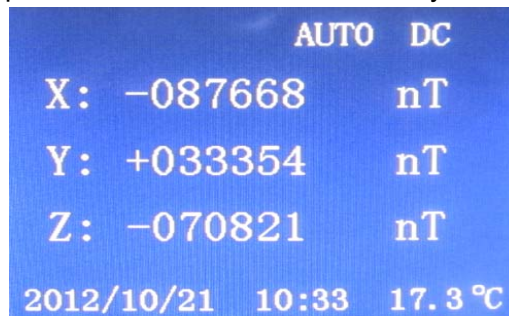
Enter: Accept changes to parameter setting

Relative: Relative mode key, record the relative values

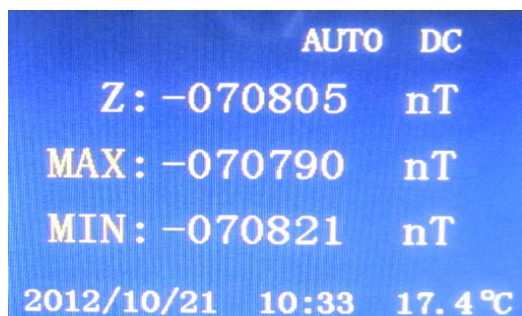
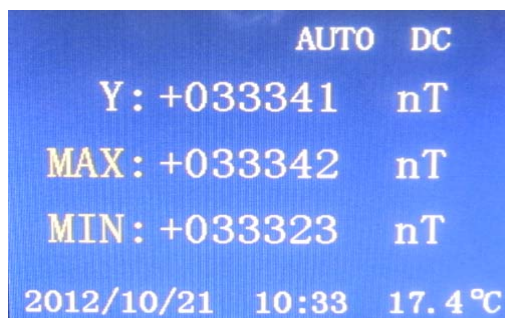
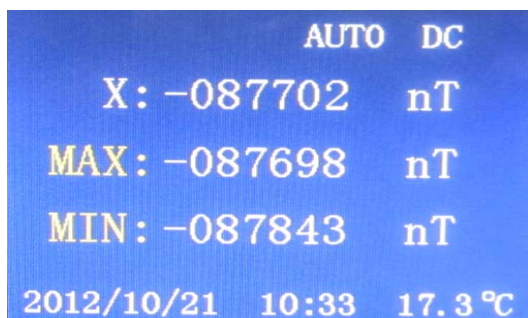
Reset: The peak reading reset. Remove the current peak readings

3.1.2 Front Panel Display

3 d display: In normal operation, the color screen display in digital mode. VGA provides the current range and measurement model on the top row and the X axis test data on the 2nd row, and the Y axis test data on the 3rd row with the Z axis test data on the fourth row and the date, time, temperature (needed to be probe with temperature sensor) and other parameters on the last row. Polarity: + means N and – means S.



1 d display: The color screen display in digital mode. VGA provides the current range, test data and the MAX/MIN data etc.



3.1.3 General Keypad Operation

Human interface with the instrument is provided by the 14 buttons that comprise the front panel keypad. Most operations can be performed through the front-panel keypad and monitored by watching the front panel display. There are three basic keypad operations:

1. **Direct Operation:** The following key functions occur upon pressing the key: **Menu, Zero, Enter, Relative, Reset.**
2. **Itinerant Operation:** The following functions will display a selection of settings immediately upon **Units, Range, Save** and **Max/Min.**
3. **Setting Selection:** Pressing the **Menu** key will enter the menu interface.

3.2 Units

The Model 330 displays magnetic field values in mG or nT. Pressing the **Units** key toggles the display between the two units.

3.3 Range

The **Range** is Auto Range mode.

3.4 Save

Pressing the **Save** key stores the data. DX-330 can store 3000 testing items of data, and when it exceeds, deletes the previous data. Data was inquired in a group of 70 items. Data Storage mode can be random(save once press the **Save** key) or auto-save interval in a setting time. Mode-setting is determined in Menu ->Save option.

3.5 Menu (single direction movement)

DX-330 provides flexible human-machine interaction. It contains powerful functions and easy accessibility in the menu. When setting Time, threshold, just move the cursor keys transversely.

3.6 Max/Min

Turn the peak reading measuring feature on and off. Capture and display the highest or lowest field readings, and hold on the interface.

Gear 1: Maximum/Minimum/CSSmax/CSSmin Holding.

Gear 2: interface locked.

Gear 3: interface unlocked.

3.7 Zero

Zero key. Put current magnetic field to Zero. (not count into the system).

Note: check-zero Mode in the menu will be count into the system.

3.8 Enter

Ensure operation key. Accepts changes to parameter setting.

3.9 Relative

Relative mode key, record the relative values (zeroing the test value).

3.10 Reset

Reset button is used to remove the current peak readings. DX-330 will reset when turned on.

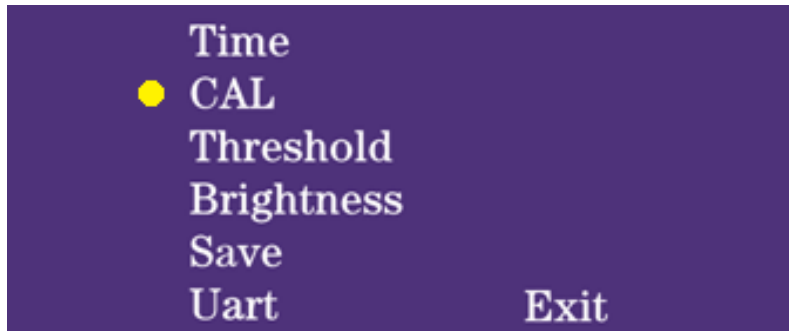
3.11 ▼▲

Toggles between various settings shown in the display and increments/decrements a numerical display.

Time	时间设定
Cal	厂家校正
Threshold	阈值设定
Brightness	高度调节
Save	存储设定
Uart	波特率设定并发数据
Exit	退出

Figure 3-2 DX-330 3D flux-gate magnetometer menu sketch

3.12 Menu function-describing



Use the up and down button to choose, and "●" means it has been selected.

3.12.1 Time setting

Press **Enter**, and then **Menu** to move the black cursor from left to right, and through the ▼▲ key to adjust the date and time. After confirmation move the cursor to Exit and press Enter to exit, that will finish the time setting.

3.12.2 Cal check

Only for the manufactory (with password to enter)

3.12.3 Threshold value setting

Press Enter key to enter and through the ▼▲ key to choose the X, Y, Z dimensions. Press the Menu key to move the cursor (yellow), and through the ▼▲ key to select the input data. It is accurate to 1nT. After setting the Range, move the cursor to Exit and press **Enter** to exit, that will finish the Threshold setting. Out of range will cause the alarm.

3.12.4 Brightness Settings

Press **Enter** to enter, then press **▼▲** key to choose proper value, and press **Enter** key to exit.

3.12.5 Save setting

Save Timing: Press **Enter** key to enter the interface, then use the **▼▲** key to set time interval of 1-60s for save data. The time interval is adjustable in 1-60s. Press **Enter** to exit.

Random Save: Press **Enter** key to ensure, every time pressing the **Save** key on the front panel will cause a data save operation.

Clear Save: After selected, press **Enter** to clear all stored data.

3.12.6 UART baud rate select and send data.

Press **Enter**, and through the **▼▲** key to select the baud rate(the baud rate should be the same with the PC serial port's baud rate). Press **Enter** to start sending data. Ending the transmitting will cause a hint: transmit over. Press **Enter** to exit.

3.13 PROBE CONSIDERATIONS

To avoid damage and for best results during use, the probes have a number of handling and accuracy requirements that must be observed. Changing probes is discussed in Paragraph 3.13.1. Probe handling is discussed in Paragraph 3.13.2. Probe operation is discussed in Paragraph 3.13.3. Finally, accuracy considerations are provided in Paragraph 3.13.4.

3.13.1 Changing Probes

DX-330 use Dexing series thin flux-gate probes.

CAUTION: The probe must be connected to the rear of the instrument before applying power to the flux-gate magnetometer. Probe memory may be erased if connected with power on. To change probes, first turn power off, remove the existing probe, and then plug in the new probe. When power is restored, the characteristics of the new probe are downloaded to the flux-gate magnetometer memory. Normal operation may continue after the new probe offset is nulled using the Zero Probe operation.

If the instrument is powered up with no probe attached, the following message is displayed.

NO	PROBE
----	-------

3.13.2 Probe Handling

Although every attempt has been made to make the probes as sturdy as possible, the probes are still fragile. This is especially true for the exposed sensor tip of some transverse probes. Care should be taken during measurements that no pressure is placed on the tip of the probe. The probe should only be held in place by securing at the handle. The probe stem should never have force applied. Any strain on the sensor may alter the probe calibration, and excessive force may destroy the Hall generator.

CAUTION: Care must be exercised when handling the probe. The tip of the probe is very fragile. Stressing the Hall sensor can alter its calibration. Any excess force can easily break the sensor. Broken sensors are not repairable.

Avoid repeated flexing of the stem of a flexible probe. As a rule, the stem should not be bent more than 45° from the base. Force should never be applied to the tip of the probe. On all probes, do not pinch or allow cables to be struck by any heavy or sharp objects. Although damaged or severed cables can be repaired, please understand that probes are not always repairable.

When probes are installed on the flux-gate magnetometer but not in use, the probes should be stored separately in some type of rigid container.

3.13.3 Probe Operation

In the DC mode of operation, the orientation of the probe affects the polarity reading of the flux-gate magnetometer.

NOTE: For best results, the instrument and probe should warm up for at least 5 minutes before zeroing the probe, and at least 30 minutes for rated accuracy. The probe and the zero gauss chamber should be at the same temperature.

If the exact direction of the magnetic field is unknown, the proper magnitude is determined by turning on **Max Hold** and slowly adjusting the probe. As the probe turns and the measured field rises and falls, its maximum value is held on the display. Make note of the probe orientation at the maximum reading to identify the field orientation.

N pole: + (display) S pole :-(display)

3.13.4 Probe Accuracy Considerations

NOTE: Probe readings are dependent upon the angle of the sensor in relation to the magnetic field. The farther from 90° the angle between the probe and the field, the greater the percentage of error.

NOTE: For best results, the instrument and probe should warm up for at least 15 minutes before zeroing the

probe, and at least 30 minutes for rated accuracy. The probe and the zero gauss chamber should be at the same temperature. The user must consider all the possible contributors to the accuracy of the reading. Both the probe and flux-gate magnetometer have accuracy specifications that may impact the actual reading. The probe should be zeroed before making critical measurements. The zero probe function is used to null (cancel) out the zero offset of the probe or small magnetic fields. Probe temperature can also affect readings. Please keep it in the temperature of 20°C while it is functioning. Probe readings are dependent on the angle of the sensor (Hall sensor) in relation to the magnetic field. Maximum output occurs when the flux vector is perpendicular to the plane of the sensor. This is the condition that exists during factory calibration. The greater the deviation from orthogonality (from right angles in either of three axes), the larger the error of the reading. See Figure 3-3. Tolerance of instrument, probe, and magnet must be considered for making critical measurements. The accuracy of the flux-gate magnetometer reading is better than $\pm 0.50\%$ of reading. Absolute accuracy readings for flux-gate magnetometer and Hall probes is a difficult specification to give, because all the variables of the measurement are difficult to reproduce. For example, a 1° error in alignment to the magnetic field causes a 0.15% reading error. Finally, the best probes have an accuracy of $\pm 0.15\%$. This implies that the absolute accuracy measurement of a magnetic field is not going to reliably be better than $\pm 0.50\%$ under the best of circumstances.

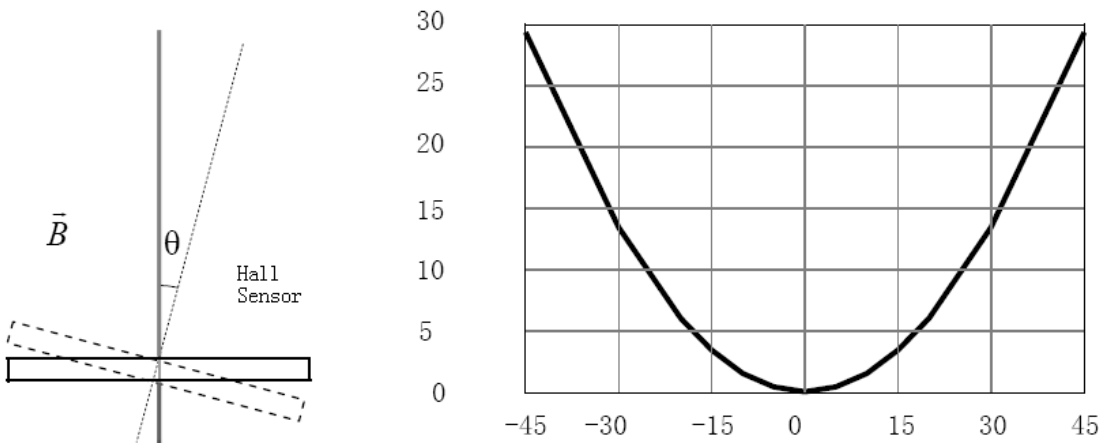


Figure 3-3 Effect Of Angle On Measurements

Note:

- 1) The high-precision measurement of the magnetic should consider the environment interference, and the stability of laboratory power supplies.
- 2) If test the objects in multi-point magnetic intensity, you should keep the probe fixed, measured things moving.

CHAPTER 4 REMOTE OPERATION

4.0 GENERAL

The Model 330 is equipped with an RS-232C serial computer interface. The interface allows computer automation of field measurement data collection and data saving and data drawing with the specific software.

4.1 SERIAL INTERFACE OVERVIEW

The serial interface used in the Model 330 is commonly referred to as an RS-232C interface. RS-232C is a standard of the Electronics Industries Association (EIA) that describes one of the most common interfaces between computers and electronic equipment. The RS-232C standard is quite flexible and allows many different configurations. The remainder of this paragraph briefly describes the key features of a serial interface that are supported by the instrument. A customer supplied computer with similarly configured interface port is required to enable communication

4.1.1 Physical Connection

The Model 330 has a 9 pin D-Subminiature plug on the rear panel for serial communication. The original RS-232C standard specifies 25 pins but both 9- and 25-pin connectors are commonly used in the computer industry. Many third party cables exist for connecting the instrument to computers with either 9- or 25-pin connectors. Paragraph 6.4 gives the most common pin assignments for 9- and 25-pin connectors. Please note that not all pins or functions are supported by the Model 330.

The instrument serial connector is the plug half of a mating pair and must be matched with a socket on the cable. If a cable has the correct wiring configuration but also has a plug end, a “gender changer” can be used to mate two plug ends together.

The letters DCE near the interface connector stand for Data Communication Equipment and indicate the pin connection of the directional pins such as transmit data (TD) and receive data (RD). Equipment with Data



Dexing Magnet Tech. Co., Ltd

Terminal Equipment (DTE) wiring can be connected to the instrument with a straight through cable. As an example, pin 2 of the DCE connector holds the transmit line and pin 2 of the DTE connector holds the receive line so the functions complement, and pin 3 of the DCE connector holds the receive line and pin 3 of the DTE connector holds the transmit line so the functions complement. It is likely PC piece of equipment is wired in the DTE configuration of 9 pins with D type. the equipment will be available for use with straight through cable.

It is likely both pieces of equipment are wired in the DCE configuration. In this case pin 3 on one DCE connector (used for transmit) must be wired to pin 2 on the other (used for receive). Cables that swap the complementing lines are called null modem cables and must be used between two DCE wired devices. Null modem cables can also be use between two DTC wired devices. Null modem adapters are also available for use with straight through cables.

The instrument uses drivers to generate the transmission voltage levels required by the RS-232C standard. These voltages are considered safe under normal operating conditions because of their relatively low voltage and current limits. The drivers are designed to work with cables up to 50 feet in length.

4.1.2 Hardware Support

The Model DX-330 interface hardware supports the following features. Asynchronous timing is used for the individual bit data within a character. This timing requires start and stop bits as part of each character so the transmitter and receiver can resynchronized between each character. Half duplex transmission allows the instrument to be either a transmitter or a receiver of data but not at the same time. Communication speeds of 19200, 57600 or 115200 baud are supported. The Baud rate is the only interface parameter that can be changed by the user.

4.1.3 Character Format

A character is the smallest piece of information that can be transmitted by the interface. Each character is 10 bits long and contains data bits and bits for character timing. The instrument uses 8 bits for data. One start bit and one stop bit are necessary to synchronize consecutive characters. Parity is a method of error detection. One parity bit configured for odd parity is not included in each character.

Table 4-1. DX-330 Serial Interface Specifications

Connector Type:	9-pin D-style Female
Connector Wiring:	DCE
Voltage Levels:	EIA RS-232C Specified
Transmission Distance:	50 feet maximum
Timing Format:	Asynchronous
Transmission Mode:	Half Duplex



Dexing Magnet Tech. Co., Ltd

Baud Rate:	19200,57600,115200
Handshake:	Software timing
Character Bits:	1 Start, 8 Data, , 1 Stop
Parity:	none
Terminators:	CR(0DH)
Command Rate:	10 commands per second maximum

4.1.4 Trouble Shooting

New Installation with communication failures

1. Check instrument baud rate
2. Make sure transmit (TD) signal line from the instrument is routed to receive (RD) on the computer and vice versa. (Use a null modem adapter if not).

Old Installation No Longer Working

1. Power instrument off then on again to see if it is a soft failure.
2. Power computer off then on again to see if communication port is locked up.
3. Verify that baud rate has not been changed on the instrument during a memory reset.
4. Check all cable connections.

Intermittent Lockups

1. Check cable connections and length.

4.1.5 Computer Control Command

1. Get data

- 1) Function: Get data from flux-gate magnetometer
- 2) Command format: "DATA?>"
- 3) Return: real-time data

Real-time measurement data format: #x value/Y value/Z value>, such as: #+00387/-00598/+00256>

2. Stop Getting data

- 1) Function: Stop the data sending of flux-gate magnetometer
- 2) Command format: "DATAC>"
- 3) Return: "ACK"

3. Query units

- 1) Function: Get current displayed unit
- 2) Command format: "UNIT?>"
- 3) Return: "ACK"+ unit, unit: "mG", "nT"

4. Set units



- 1) Function: Set displayed unit.
 - 2) Command format: "UNITSET>"
 - 3) Return: "ACK"
5. Query upper threshold X
- 1) Function: Get the upper limit of the threshold of X.
 - 2) Command format: "UPTHRES?X>"
 - 3) Return: "ACK" + the upper limit of the threshold of X
6. Query upper threshold Y
- 1) Function: Get the upper limit of the threshold of Y.
 - 2) Command format: "UPTHRES?Y>"
 - 3) Return: "ACK" + the upper limit of the threshold of Y
7. Query upper threshold Z
- 1) Function: Get the upper limit of the threshold of Z.
 - 2) Command format: "UPTHRES?Z>"
 - 3) Return: "ACK" + the upper limit of the threshold of Z
8. Query lower threshold X
- 1) Function: Get the lower limit of the threshold of X.
 - 2) Command format: "UPTHRES?X>"
 - 3) Return: "ACK" + the lower limit of the threshold of X
9. Query lower threshold Y
- 1) Function: Get the lower limit of the threshold of Y.
 - 2) Command format: "UPTHRES?Y>"
 - 3) Return: "ACK" + the lower limit of the threshold of Y
10. Query lower threshold Z
- 1) Function: Get the lower limit of the threshold of Z.
 - 2) Command format: "UPTHRES?Z>"
 - 3) Return: "ACK" + the lower limit of the threshold of Z
11. Zero
- 1) Function: Zero the values of three axes at the same time
 - 2) Command format: "ZERO>"
 - 3) Return: "ACK"
12. Set upper threshold X
- 1) Function: Set the upper limit of the threshold of X
 - 2) Command format: "X_UPTHRES+/-xxxx>"
 - 3) Return: "ACK"
- Such as: "X_UPTHRES+3000.00>"
13. Set lower threshold X
- 1) Function: Set the lower limit of the threshold of X
 - 2) Command format: "X_UPTHRES+/-xxxx>"
 - 3) Return: "ACK"



Dexing Magnet Tech. Co., Ltd

Such as: "X_LOWTHRES -3000.00>"

14. Set upper threshold Y

- 1) Function: Set the upper limit of the threshold of Y
- 2) Command format: "Y_UPTHRES+/-xxxxx>"
- 3) Return: "ACK"

15. Set lower threshold Y

- 1) Function: Set the lower limit of the threshold of Y
- 2) Command format: "Y_UPTHRES+/-xxxxx>"
- 3) Return: "ACK"

16. Set upper threshold Z

- 1) Function: Set the upper limit of the threshold of Z
- 2) Command format: "Z_UPTHRES+/-xxxxx>"
- 3) Return: "ACK"

17. Set lower threshold Z

- 1) Function: Set the lower limit of the threshold of Z
- 2) Command format: "Z_UPTHRES+/-xxxxx>"
- 3) Return: "ACK"

4.1.6 Connect to Software

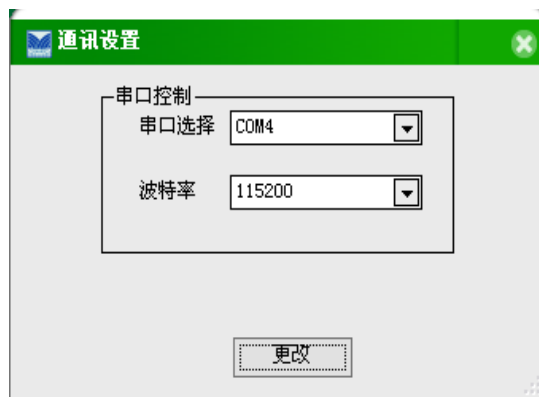
DX-330 communicates with computer by RS232.

Serial port connect: If your computer has serial port, you can connect it to flux-gate magnetometer directly; Or you have to use USB to RS232 converter.

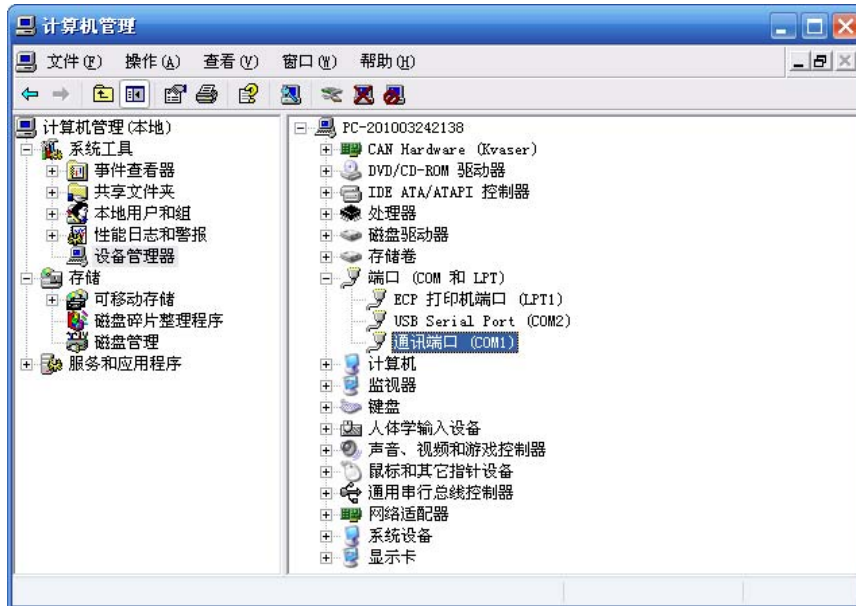


Figure 4-1 3D Data Read and Draw Main Form

Communicate Setting:



Com Port: Set the serial port number of device that connects to the computer. If you are not sure about it, please right click “my computer” ->govern>device



manager->(COM and LPT), then you'll get it, which is shown in Figure 4-2.

Figure 4-2 number of serial port

Baud Rate: The default of the baud rate of serial port is 115200.If you've changed the baud rate in the flux-gate magnetometer, you must choose the same value in software to keep them same, or the computer won't get the data from the flux-gate magnetometer

After finish the above setting correctly, click the button “Start” to begin the data reading. The software will give you a prompt that succeed in connecting the flux-gate magnetometer. It is shown in Figure 4-3.



Dexing Magnet Tech. Co., Ltd

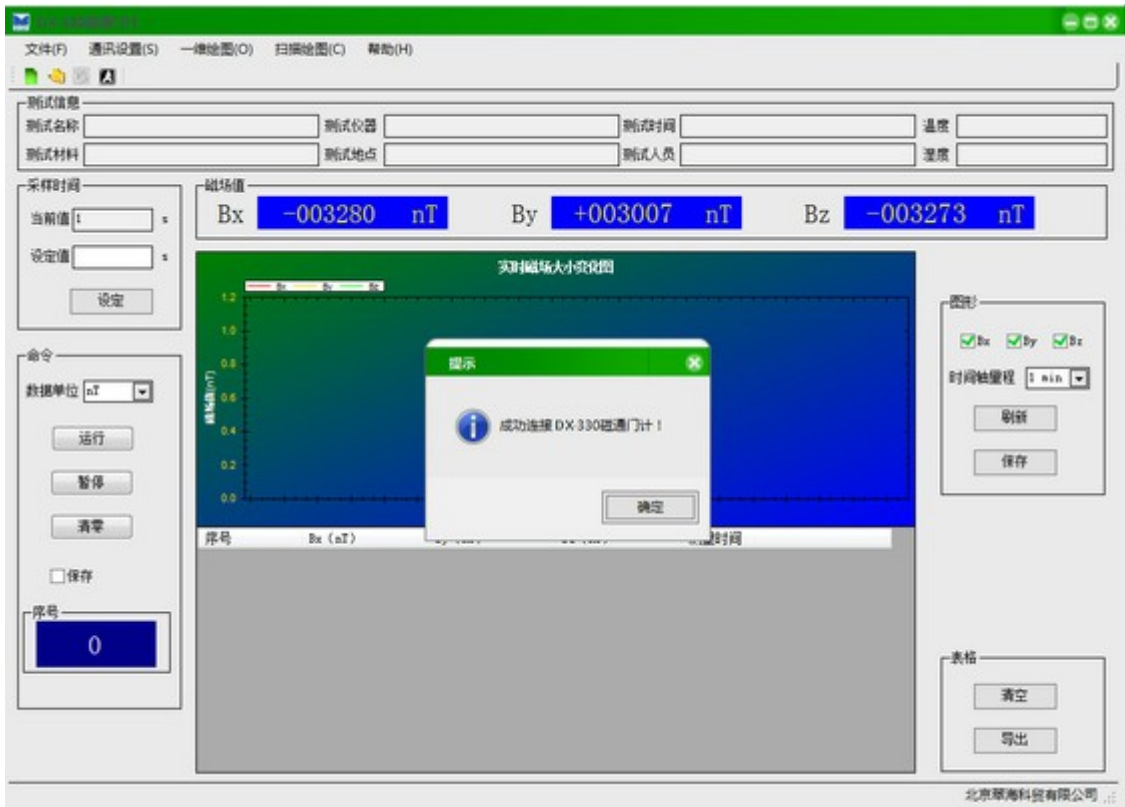


Figure 4-3 Information of Connect

CHAPTER 5 ACCESSORIES

5.0 GENERAL

This chapter provides the attachment information of Model 330 flux-gate magnetometer.

5.1 ACCESSORIES

Accessories are devices that perform a secondary duty as an aid or refinement to the primary unit. A list of accessories available for the Model 330 are as follows:

Table 5-1 DX-330 accessories

Model	Description
Model-3AD802F	3 d digital flux-gate probe with measuring range of 100000nT one
220-10	3-pin 220V single-phase AC power cord one
RS232-DCE9	Straight-through 9-pin RS-232C serial communication cable one
MAN-330	DX-330 User Manual one Calibration certificates one Warranty one

At the same time, users can select for DX-330 accessory of *RS232-USB to change RS232 interface to USB interface in case of USB bus control using, which will upgrade the PC controlled equipment. *Optional Gauss Meter professional mapping software promotes to data storage and rendering of professional charts.

Dexing Magnet Tech.Co.,Ltdreserve the right to change the foregoing accessory Specification without notice.

5.2 CABLE

DX-330 is delivered with 232-C9 straight through cable.



5.3 Rittal

Through the use of cabinets to install components, DX-330 can be a standard 19-inch standard rack mounted chassis way inside.

CHAPTER 6 OPTIONAL PARTS

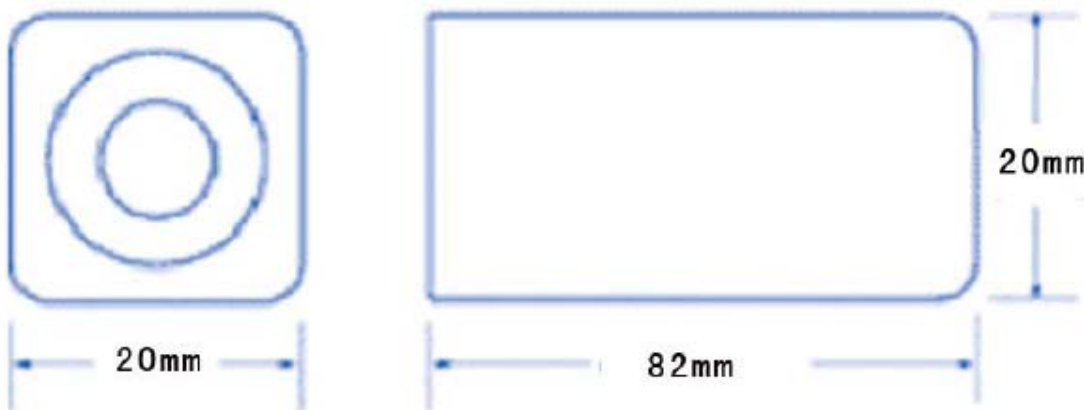
6.0 General

This chapter provides general optional parts of Dexing Magnet Tech.Co.,Ltd

6.1 Dexing Magnet Tech.Co.,Ltd Zero gauss chamber

Zero gauss chamber commonly used in adjusting the probe, the probe is located in a relative zero magnetic field environment and thereby to detect the magnetic field relative to the zero value.

Zero gauss chamber



6.2 Dexing Magnet Tech.Co.,Ltd Gauss Meter Professional mapping software

Dexing Magnet Tech.Co.,Ltd specially designed the multi-px-1 mapping software that is suitable for flux-gate magnetometer for measuring, storage and mapping.



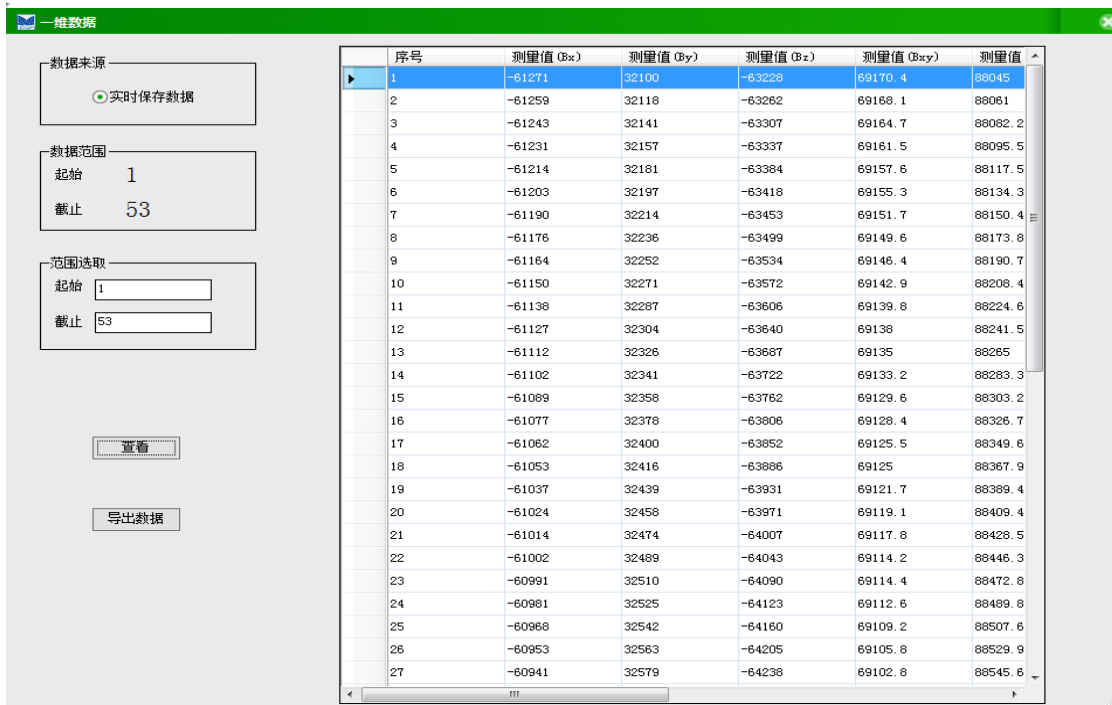
Dexing Magnet Tech. Co., Ltd



Characteristics

*Automatic saving data

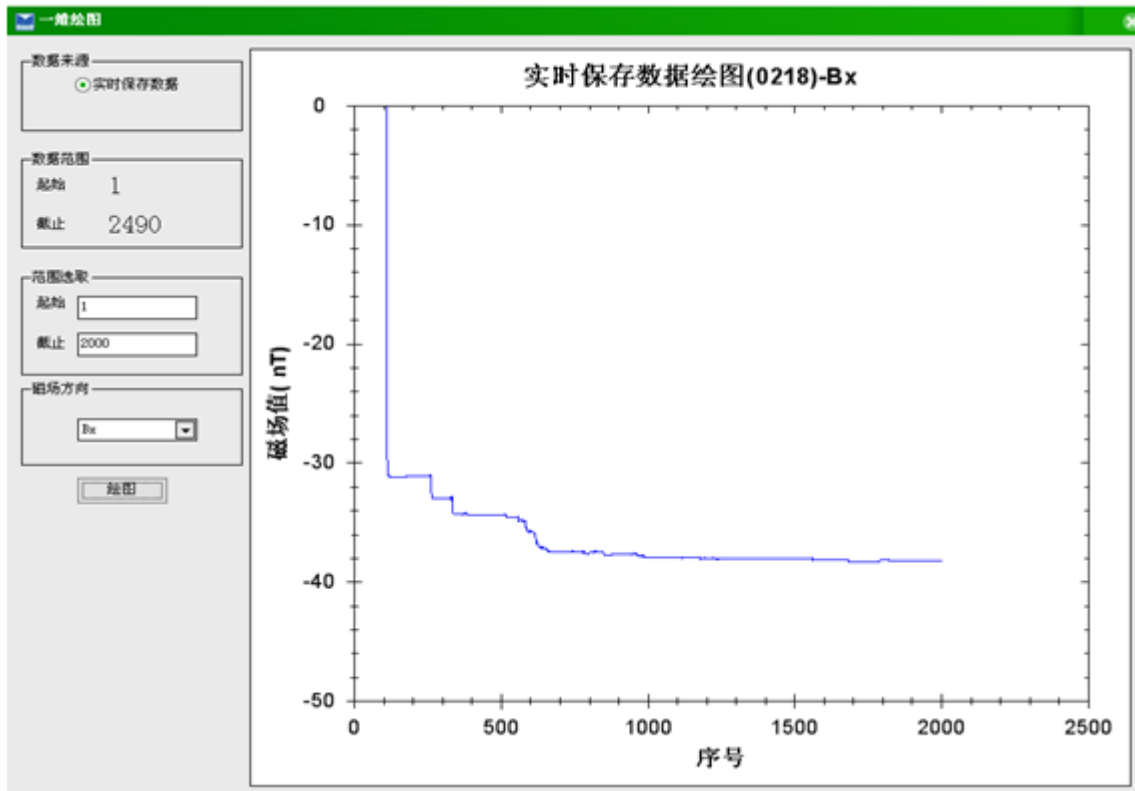
Mapping software can automatically put data into the software database, to facilitate the instant query.



Add: No.300-402, Rd. West Jinshan, Huli Dist. Xiamen,China Zip code: 361015
 Tel: 86-592-5237772 Fax: 86-592-5237901
 Email: sales@magnetsource.com.cn

*Extract data mapping

Mapping software extracts data mapping support, so that useful data segment will be used to draw graphics.



Drawing coordinates can be choice according to the data range. It can choose direction of magnetic field from Bx, By, Bz, Bxy, Byz, Bxz, B. In order to accurately draw the detection of graphics, graphics software's axes, the y-axis and the x-axis can be arbitrarily set. Y is defined as: magnetic field intensity (nT) nT, X-axis is defined as: the data axis.

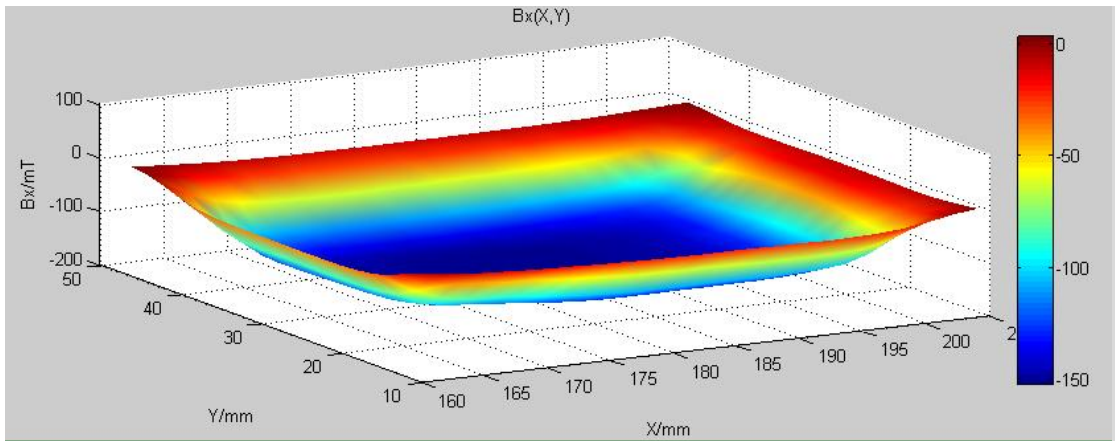
You can measure the scope of data to set the Y-axis scale, so you draw graphics clearer, highest resolution graphics. Unique graphics concept, more convenient mapping mode, makes the magnetic measurement of the data more intuitive.

Drawing coordinates can be choice according to the data range. It can choose direction of magnetic field from Bx, By, Bz, Bxy, Byz, Bxz, B. In order to accurately draw the detection of graphics, graphics software's axes, the y-axis and the x-axis can be arbitrarily set. Y is defined as: magnetic field intensity (nT) nT, X-axis is defined as: the data axis.

You can measure the scope of data to set the Y-axis scale, so you draw graphics clearer, highest resolution graphics. Unique graphics concept, more convenient mapping mode, makes the magnetic measurement of the data more intuitive.



Dexing Magnet Tech. Co., Ltd



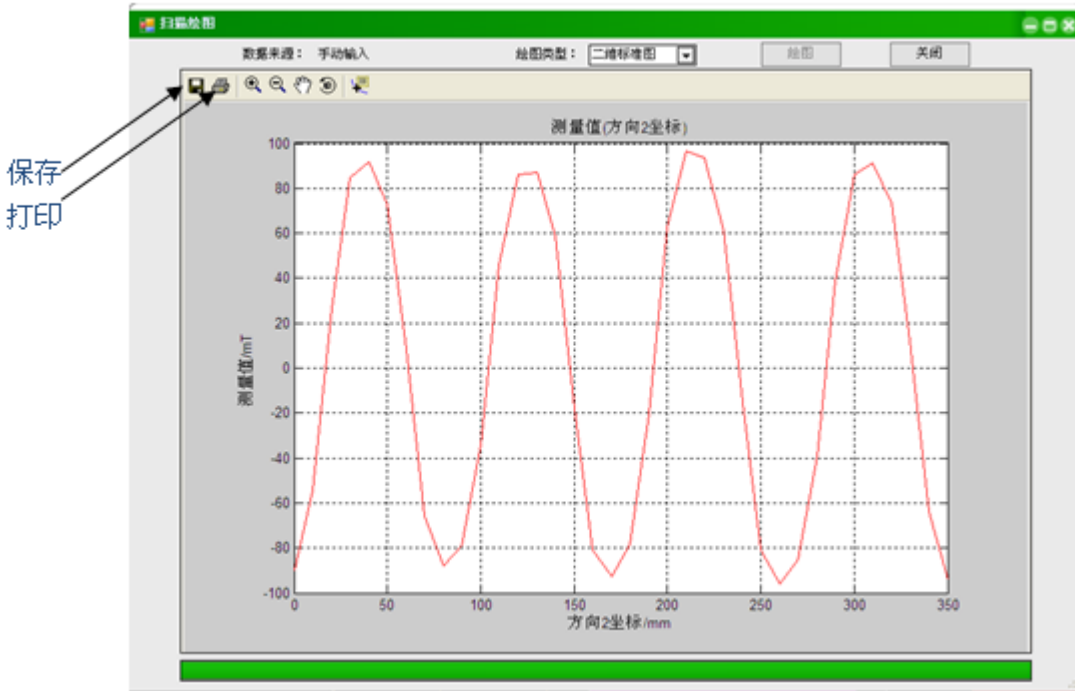
Database View

Graphics software support database view through access2003/07 and Excel2003/07 series versions.

序号	测量值(Bx)	测量值(By)	测量值(Bz)	测量值(Bxy)	测量值(Bxz)	测量值(Byz)	测量值(B)	角度值1	角度值2	测量时间
1	-61271	32100	-63228	69170.4	88045	70909.7	93714.1	132.3999939	152.3000031	2012/10/21 15:35:42
2	-61259	32118	-63262	69168.1	88061	70948.2	93735.3	132.3999939	152.3000031	2012/10/21 15:35:43
3	-61243	32141	-63307	69164.7	88082.2	70998.7	93763.1	132.5	152.3000031	2012/10/21 15:35:44
4	-61231	32157	-63337	69161.5	88098.5	71032.7	93781	132.5	152.3000031	2012/10/21 15:35:45
5	-61214	32181	-63384	69157.6	88117.5	71085.5	93809.9	132.5	152.3000031	2012/10/21 15:35:46
6	-61203	32197	-63418	69155.3	88134.3	71123.1	93831.2	132.5	152.3000031	2012/10/21 15:35:47
7	-61190	32214	-63453	69151.7	88150.4	71162	93852.2	132.5	152.1999969	2012/10/21 15:35:48
8	-61176	32236	-63499	69149.6	88173.8	71212.9	93881.8	132.6000061	152.1999969	2012/10/21 15:35:49
9	-61164	32252	-63534	69146.4	88190.7	71251.4	93903.1	132.6000061	152.1999969	2012/10/21 15:35:50
10	-61150	32271	-63572	69142.9	88208.4	71293.9	93926.2	132.6000061	152.1999969	2012/10/21 15:35:51
11	-61138	32287	-63606	69139.8	88224.6	71331.4	93946.9	132.6000061	152.1999969	2012/10/21 15:35:52
12	-61127	32304	-63640	69139	88241.5	71369.4	93968.7	132.6000061	152.1000061	2012/10/21 15:35:53
13	-61112	32326	-63687	69135	88265	71421.3	93998.3	132.6999969	152.1000061	2012/10/21 15:35:54
14	-61102	32341	-63722	69133.2	88283.3	71459.3	94020.7	132.6999969	152.1000061	2012/10/21 15:35:55
15	-61089	32358	-63762	69129.6	88303.2	71502.7	94045.2	132.6999969	152.1000061	2012/10/21 15:35:56
16	-61077	32378	-63806	69128.4	88326.7	71551	94074.1	132.6999969	152.1000061	2012/10/21 15:35:57
17	-61062	32400	-63852	69125.5	88349.6	71601.9	94103.2	132.6999969	152.2012/10/21	15:35:58
18	-61053	32416	-63886	69125	88367.9	71639.5	94125.9	132.6999969	152.2012/10/21	15:35:59
19	-61037	32439	-63931	69121.7	88389.4	71690	94154	132.8000031	152.2012/10/21	15:36:00
20	-61024	32458	-63971	69119.1	88409.4	71734.3	94179.3	132.8000031	152.2012/10/21	15:36:01
21	-61014	32474	-64007	69117.8	88428.5	71773.6	94202.8	132.8000031	152.2012/10/21	15:36:02
22	-61002	32489	-64043	69114.2	88446.3	71812.5	94224.7	132.8000031	152.2012/10/21	15:36:03
23	-60991	32510	-64090	69114.4	88472.8	71864	94256.7	132.8000031	151.8999939	2012/10/21 15:36:04
24	-60981	32525	-64123	69112.6	88489.8	71900.2	94277.9	132.8999939	151.8999939	2012/10/21 15:36:05
25	-60968	32542	-64160	69109.2	88507.6	71940.9	94300.5	132.8999939	151.8999939	2012/10/21 15:36:06
26	-60953	32563	-64205	69105.8	88529.9	71990.5	94328.7	132.8999939	151.8999939	2012/10/21 15:36:07
27	-60941	32579	-64238	69102.8	88545.6	72027.2	94348.9	132.8999939	151.8999939	2012/10/21 15:36:08
28	-60929	32594	-64271	69099.3	88561.3	72063.4	94368.8	132.8999939	151.8999939	2012/10/21 15:36:09
29	-60913	32616	-64317	69095.6	88583.7	72114.4	94397.4	132.8999939	151.8000031	2012/10/21 15:36:11
30	-60901	32636	-64357	69094.4	88604.5	72159.1	94423.9	133	151.8000031	2012/10/21 15:36:12
31	-60889	32653	-64392	69091.9	88621.7	72198	94445.8	133	151.8000031	2012/10/21 15:36:13
32	-60876	32670	-64429	69088.5	88639.6	72238.7	94468.6	133	151.8000031	2012/10/21 15:36:14
33	-60861	32690	-64477	69084.7	88664.2	72290.5	94498.6	133	151.8000031	2012/10/21 15:36:15

Add: No.300-402, Rd. West Jinshan, Huli Dist. Xiamen,China Zip code: 361015
 Tel: 86-592-5237772 Fax: 86-592-5237901
 Email: sales@magnetsource.com.cn

**saving and printing*



CHAPTER 7 SERVICE

7.0 GENERAL

This chapter provides general Maintenance and usage information for the Dexing Model DX-330 flux-gate magnetometer. General maintenance precautions are described in Paragraph 7.1, electrostatic discharge in Paragraph 7.2, fuse replacement in Paragraph 7.3, rear panel connector definitions in Paragraph 7.4, Serial communication cable in Paragraph 7.5.

7.1 GENERAL MAINTENANCE PRECAUTIONS

Below are general safety precautions unrelated to any other procedure in this publication.

1. Keep away from live circuits.
2. Installation personnel and operation, maintenance and repair personnel shall observe all safety regulations at all times.
3. Turn off system power before making or breaking electrical connections. And AC power cord should pull out from the power supply input component on the rear panel after out.
4. Regard any exposed connector, terminal board, or circuit board as a possible shock hazard.
5. If a test connection to energized equipment is required, make the test equipment ground connection before probing the voltage or signal to be tested. unauthorized organizations or individuals are strictly prohibited from opening instrument chassis of any form of maintenance, in order to ensure maximum personal safety and to maintain the safety performance of the instrument itself.
6. Do not install or service equipment alone. Do not reach into or adjust the equipment without having another person nearby capable of rendering aid.
7. If there is no power, verify the power cord is plugged into a live outlet and that both ends are securely plugged in. Next, check the fuse. Please refer to 6.3.
8. Before clean equipment, firstly, turn off the power, secondly, remove AC power cord and all the rear panel connections or cable from the corresponding components, adapters, or the connector.
9. Clean front and back panels and case with soft cloth dampened with a mild detergent and water solution to remove dust, grease, and other contaminants. Do not use aromatic hydrocarbons or chlorinated solvents to clean the Model DX-330. They may react with the plastic materials used in the controller or the silk screen printing on the back panel.

7.2 ELECTROSTATIC DISCHARGE

Electrostatic Discharge (ESD) may damage electronic parts, assemblies, and equipment. ESD is a transfer of electrostatic charge between bodies at different electrostatic potentials caused by direct contact or induced by an electrostatic field. The low-energy source that most commonly destroys Electrostatic Discharge Sensitive (ESDS) devices is the human body, which generates and retains static electricity. Simply walking across a carpet in low humidity may generate up to 35,000 volts of static electricity.

Current technology trends toward greater complexity, increased packaging density, and thinner dielectrics between active elements, which results in electronic devices with even more ESD sensitivity. Some electronic parts are more ESDS than others. ESD levels of only a few hundred volts may damage electronic components such as semiconductors, thick and thin film resistors, and piezoelectric crystals during testing, handling, repair, or assembly. Discharge voltages below 4000 volts cannot be seen, felt, or heard.

7.2.1 Identification of Electrostatic Discharge Sensitive Components

Below are various industry symbols used to label components as ESDS:



7.2.2 Handling Electrostatic Discharge Sensitive Components

Observe all precautions necessary to prevent damage to ESDS components before attempting installation. Bring the device and everything that contacts it to ground potential by providing a conductive surface and discharge paths. As a minimum, observe these precautions:

1. De-energize or disconnect all power and signal sources and loads used with unit.
2. Place unit on a grounded conductive work surface.
3. Ground technician through a conductive wrist strap (or other device) using 1 M series resistor to protect operator.
4. Ground any tools, such as soldering equipment, that will contact unit. Contact with operator's hands provides a sufficient ground for tools that are otherwise electrically isolated.
5. Place ESDS devices and assemblies removed from a unit on a conductive work surface or in a conductive container. An operator inserting or removing a device or assembly from a container must maintain contact with a conductive portion of the container. Use only plastic bags approved

for storage of ESD material.

6. Do not handle ESDS devices unnecessarily or remove from the packages until actually used or tested.

7.3 FUSE REPLACEMENT

Below is the procedure to remove and replace a line fuse. Test fuse with ohmmeter. Do not rely on visual inspection of fuse.

WARNING: To avoid potentially lethal shocks, turn off controller and disconnect it from AC power before performing these procedures.

CAUTION: For continued protection against fire hazard, replace only with the same fuse type.

1. Turn power switch Off (O).
2. Remove instrument power cord.
3. Identify the fuse assembly just above the power input assembly on the instrument rear panel.
4. release the drawer holding the fuse. Remove existing fuse(s). Replace with 220V/0.5A Slow-Blow fuse.
5. Re-assemble the drawer holding the fuse and Tighten.
6. Connect instrument power cord.
7. Turn power switch On (I).

NOTE: Some DX-330 used for special purposes should use the 220V/0.25A Slow-Blow fuse.

7.4 REAR PANEL CONNECTOR DEFINITIONS

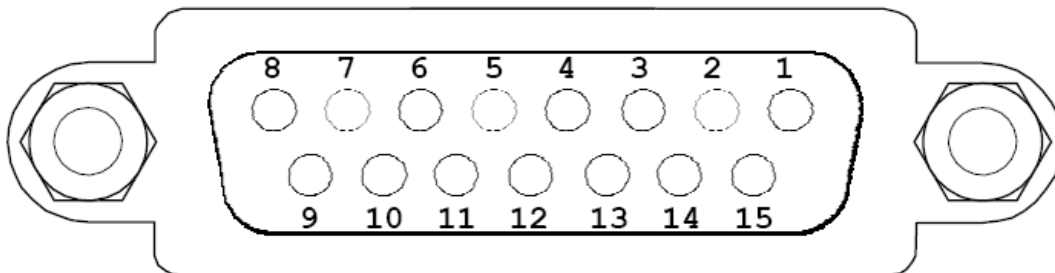


Figure 7- 1Probe Input on the rear panel

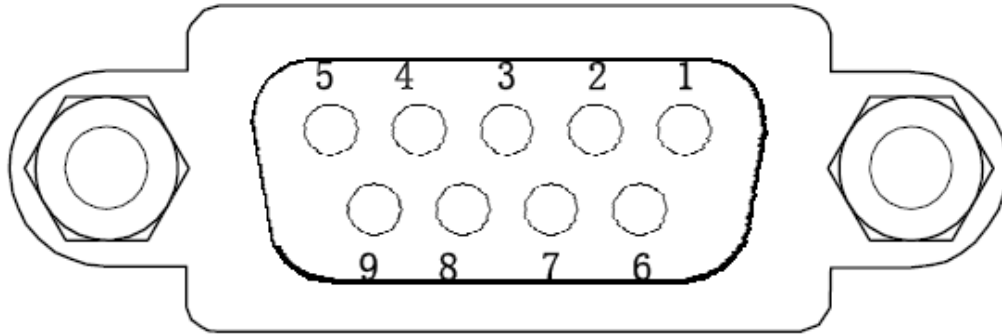


Figure 7- 2 Serial I/O Connector on the rear Panel

DX-330(DCE)		PC(DTE)			
DB-9F		DB-25M		DB-9M	
Pin No.	Description	Pin No.	Description	Pin No.	Description
1	No Connection	2	Tx	1	DCD
2	Transmit Data(Tx)	3	Rx	2	Rx
3	Receive Data(Rx)	4	RTS	3	Tx
4	No Connection	5	CTS	4	DTR
5	GND	6	DSR	5	GND
6	No Connection	7	GND	6	DSR
7	No Connection	8	DCD	7	RTS
8	No Connection	20	DTR	8	CTS
9	No Connection	22	Ring in	9	Ring in

Figure 7- 3 Serial I/O Connector Detail

7.5 Serial Interface Cable Wiring

DX-330 using a serial straight-through cable (Annex RS232-DCE9) to connect the computer's 9-pin serial interface. Under the certain cable order, It Can also use the correct adapter to connect the computer's 25-pin serial interface.

The following are suggested cable wiring diagrams for connecting the Model DX-330 Serial Interface to Customer Personal Computers (PCs).

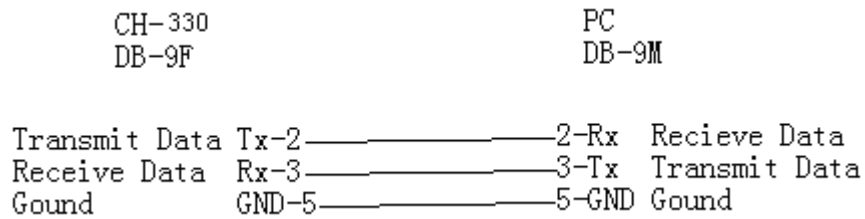


Figure 7- 4 DX-330 connect to PC 9 pin Serial I/O

APPENDIX A UNITS FOR MAGNETIC PROPERTIES

Quantity	Symbol	Gaussian and CGS emu ^a	Conversion Factor, C ^b	SI and Rationalized mks ^c
Magnetic flux density, Magnetic induction	B	gauss (G) ^d	10 ⁻⁴	tesla (T), Wb/m ²
Magnetic Flux	φ	maxwell (Mx), G·cm ²	10 ⁻⁸	weber (Wb), volt second (V·s)
Magnetic potential difference, magnetomotive force	U, F	gilbert (Gb)	10/4π	ampere (A)
Magnetic field strength, magnetizing force	H	oersted (Oe), ^e Gb/cm	10 ³ /4π	A/m ^f
(Volume) magnetization ^g	M	emu/cm ^{3h}	10 ³	A/m
(Volume) magnetization	4πM	G	10 ³ /4π	A/m
Magnetic polarization, intensity of magnetization	J, I	emu/cm ³	4π × 10 ⁻⁴	T, Wb/m ²ⁱ
(Mass) magnetization	σ, M	emu/g	$\frac{1}{4\pi \times 10^{-7}}$	A·m ² /kg Wb·m/kg
Magnetic moment	m	emu, erg/G	10 ⁻³	A·m ² , joule per tesla (J/T)
Magnetic dipole moment	j	emu, erg/G	4π × 10 ⁻¹⁰	Wb·m ^l
(Volume) susceptibility	χ, κ	dimensionless emu/cm ³	$\frac{1}{(4\pi)^2} \times 10^{-7}$	Henry per meter (H/m), Wb/(A·m)
(Mass) susceptibility	χ _p , κ _p	cm ³ /g, emu/g	$\frac{4\pi \times 10^{-3}}{(4\pi)^2} \times 10^{-10}$	m ³ /kg H·m ² /kg
(Molar) susceptibility	χ _{mol} , κ _{mol}	cm ³ /mol, emu/mol	$\frac{4\pi \times 10^{-6}}{(4\pi)^2} \times 10^{-13}$	m ³ /mol H·m ² /mol
Permeability	μ	dimensionless	4π × 10 ⁻⁷	H/m, Wb/(A·m)
Relative permeability ^j	μ _r	not defined	—	dimensionless
(Volume) energy density, energy product ^k	W	erg/cm ³	10 ⁻¹	J/m ³
Demagnetization factor	D, N	dimensionless	1/4π	dimensionless

Table A-1. Conversion from CGS to SI Units

Quantity	Symbol	Value (SI units)
Permeability of Vacuum	μ_0	$4\pi \times 10^{-7} \text{ H m}^{-1}$
Speed of Light in Vacuum	c	$2.9979 \times 10^8 \text{ m s}^{-1}$
Permittivity of Vacuum	$\epsilon_0 = (\mu_0 c^2)^{-1}$	$8.8542 \times 10^{-12} \text{ F m}^{-1}$
Fine Structure Constant, $\mu_0 c e^2 / 2h$	α α^{-1}	0.0073 137.0360
Elementary Charge	e	$1.6022 \times 10^{-19} \text{ C}$
Plank's Constant	h $h = h/2\pi$	$6.6262 \times 10^{-34} \text{ J Hz}^{-1}$ $1.0546 \times 10^{-34} \text{ J s}$
Avogadro's Constant	N_A	$6.0220 \times 10^{23} \text{ mol}^{-1}$
Atomic Mass Unit	$1 \text{ u} = 10^{-3} \text{ kg mol}^{-1} / N_A$	$1.6605 \times 10^{-27} \text{ kg}$
Electron Rest Mass	m_e	$0.9109 \times 10^{-30} \text{ kg}$ $5.4858 \times 10^{-4} \text{ u}$
Proton Rest Mass	m_p	$1.6726 \times 10^{-27} \text{ kg}$ 1.0073 u
Neutron Rest Mass	m_n	$1.6749 \times 10^{-27} \text{ kg}$ 1.0087 u
Magnetic Flux Quantum	$\phi = h/2e$ h/e	$2.0679 \times 10^{-15} \text{ Wb}$ $4.1357 \times 10^{-15} \text{ J Hz}^{-1} \text{ C}^{-1}$
Josephson Frequency-Voltage Ratio	$2e/h$	$483.5939 \text{ THz V}^{-1}$
Quantum of Circulation	$h/2m_e$ h/m_e	$3.6369 \times 10^{-4} \text{ J Hz}^{-1} \text{ kg}^{-1}$ $7.2739 \times 10^{-4} \text{ J Hz}^{-1} \text{ C}^{-1}$
Rydberg Constant	R_∞	$1.0974 \times 10^7 \text{ m}^{-1}$
Proton Moment in Nuclear Magnetons	μ_p / μ_N	2.7928
Bohr Magneton	$\mu_B = eh/2m_e$	$9.2741 \times 10^{-24} \text{ J T}^{-1}$
Proton Gyromagnetic Ratio	γ_p	$2.6752 \times 10^8 \text{ s}^{-1} \text{ T}^{-1}$
Diamagnetic Shielding Factor, Spherical H ₂ O Sample	$1 + \sigma(\text{H}_2\text{O})$	1.0000
Molar Mass Constant	R	$8.3144 \text{ J mol}^{-1} \text{ K}^{-1}$
Molar Volume, Ideal Gas ($T_0 = 273.15\text{K}$, $p_0 = 1 \text{ atm}$)	$V_m = RT_0/p_0$	$0.0224 \text{ m}^3 \text{ mol}^{-1}$
Boltzman Constant	$k = R/N_A$	$1.3807 \times 10^{-23} \text{ J K}^{-1}$
Stefan-Boltzman Constant	$\sigma = (\pi^2/60) k^4/h^3 c^2$	$5.6703 \times 10^{-8} \text{ W m}^{-2} \text{ K}^{-4}$
First Radiation Constant	$c_1 = 2\pi hc^2$	$3.7418 \times 10^{-16} \text{ W m}^{-2}$
Second Radiation Constant	$c_2 = hc/k$	0.0144 mK
Gravitation Constant	G	$6.6720 \times 10^{-11} \text{ N m}^2 \text{ kg}^{-2}$

Table A-2. Recommended SI Values for Physical Constants



APPENDIX B GLOSSARY OF TERMINOLOGY

accuracy. The degree of correctness with which a measured value agrees with the true value.²

American Standard Code for Information Exchange (ASCII). A standard code used in data transmission, in which 128 numerals, letters, symbols, and special control codes are represented by a 7-bit binary number as follows:

Bits					Col.									
b ₇	b ₆	b ₅	b ₄	b ₃	b ₂	b ₁	0 ₀	0 ₀	0 ₁	0 ₁	1 ₀	1 ₀	1 ₁	1 ₁
1	1	1	1	1	1	1	0	1	2	3	4	5	6	7
0	0	0	0	0	0	0	NUL	DLE	SP	0	'	P	@	p
0	0	0	1	1	1	1	SOH	DC1	!	1	A	Q	a	q
0	0	1	0	0	0	0	STX	DC2	"	2	B	R	b	r
0	0	1	1	1	1	1	ETX	DC3	#	3	C	S	c	s
0	1	0	0	0	0	0	EOT	DC4	\$	4	D	T	d	t
0	1	0	1	1	1	1	ENG	NAK	%	5	E	U	e	u
0	1	1	0	0	0	0	ACK	SYN	&	6	F	V	f	v
0	1	1	1	1	1	1	BEL	ETB	'	7	G	W	g	w
1	0	0	0	0	0	0	BS	CAN	(8	H	X	h	x
1	0	0	1	1	1	1	HT	EM)	9	I	Y	i	y
1	0	1	0	0	0	0	LF	SS	*	:	J	Z	j	z
1	0	1	1	1	1	1	VT	ESC	+	;	K	[k	(
1	1	0	0	0	0	0	FF	FS	,	<	L	~	l	_
1	1	0	1	1	1	1	CR	GS	-	=	M]	m)
1	1	1	0	0	0	0	SO	RS	.	>	N	^	n	
1	1	1	1	1	1	1	SI	US	/	?	O	—	o	DEL

American Wire Gage (AWG). Wiring sizes are defined as diameters in inches and millimeters as follows:

AWG Dia. In.	Dia. mm	AWG	Dia. In.	Dia. Mm	AWG Dia. In.	Dia. mm	AWG	Dia. In.	Dia. mm		
1	0.2893	7.348	11	0.0907	2.304	21	0.0285	0.7230	31	0.0089	0.2268
2	0.2576	6.544	12	0.0808	2.053	22	0.0253	0.6438	32	0.0080	0.2019
3	0.2294	5.827	13	0.0720	1.829	23	0.0226	0.5733	33	0.00708	0.178
4	0.2043	5.189	14	0.0641	1.628	24	0.0207	0.5106	34	0.00630	0.152
5	0.1819	4.621	15	0.0571	1.450	25	0.0179	0.4547	35	0.00561	0.138
6	0.1620	4.115	16	0.0508	1.291	26	0.0159	0.4049	36	0.00500	0.127
7	0.1443	3.665	17	0.0453	1.150	27	0.0142	0.3606	37	0.00445	0.1131
8	0.1285	3.264	18	0.0403	1.024	28	0.0126	0.3211	38	0.00397	0.1007
9	0.1144	2.906	19	0.0359	0.9116	29	0.0113	0.2859	39	0.00353	0.08969
10	0.1019	2.588	20	0.0338	0.8118	30	0.0100	0.2546	40	0.00314	0.07987

ampere. The constant current that, if maintained in two straight parallel conductors of infinite length, of negligible circular cross section, and placed one meter apart in a vacuum, would produce between these conductors a force equal to 2×10^{-7} newton per meter of length.² This is one of the base units of the SI.

ampere/meter (A/m). The SI unit for magnetic field strength (H). 1 ampere/meter = 4 /1000 oersted \approx 0.01257 oersted.

analog output. A voltage output from an instrument that is proportional to its input. From an instrument such as a digital voltmeter,



Dexing Magnet Tech. Co., Ltd

the output voltage is generated by a digital-to-analog converter with a discrete number of voltage levels.

B. Symbol for magnetic flux density. See Magnetic Flux Density.

baud. A unit of signaling speed equal to the number of discrete conditions or signal events per second, or the reciprocal of the time of the shortest signal element in a character.²

bit. A contraction of the term “binary digit”; a unit of information represented by either a zero or a one.²

Celsius (°C) Scale. A temperature scale that registers the freezing point of water as 0 °C and the boiling point as 100 °C under normal atmospheric pressure. Celsius degrees are purely derived units, calculated from the Kelvin Thermodynamic Scale. Formerly known as “centigrade.” See Temperature for conversions.

deviation. The difference between the actual value of a controlled variable and the desired value corresponding to the setpoint.¹

drift, instrument. An undesired but relatively slow change in output over a period of time, with a fixed reference input.

Note: Drift is usually expressed in percent of the maximum rated value of the variable being measured.²

electron. An elementary particle containing the smallest negative electric charge. *Note:* The mass of the electron is approximately equal to 1/1837 of the mass of the hydrogen atom.²

electrostatic discharge (ESD). A transfer of electrostatic charge between bodies at different electrostatic potentials caused by direct contact or induced by an electrostatic field.

error. Any discrepancy between a computed, observed, or measured quantity and the true, specified, or theoretically correct value or condition.²

gauss (G). The cgs unit for magnetic flux density (B). 1 gauss = 10⁻⁴ tesla = 1 Mx/cm² = line/cm². Named for Karl Fredrich Gauss (1777 – 1855) a German mathematician, astronomer, and physicist.

Greek alphabet. The Greek alphabet is defined as follows:

Alpha	α	A	Iota	ι	I	Rho	ρ	P
Beta	β	B	Kappa	κ	K	Sigma	σ	Σ
Gamma	γ	Γ	Lambda	λ	Λ	Tau	τ	T
Delta	δ	Δ	Mu	μ	M	Upsilon	υ	Υ
Epsilon	ε	E	Nu	ν	N	Phi	φ	Φ
Zeta	ζ	Z	Xi	ξ	Ξ	Chi	χ	X
Eta	η	H	Omicron	ο	O	Psi	ψ	Ψ
Theta	θ	Θ	Pi	π	Π	Omega	ω	Ω

ground. A conducting connection, whether intentional or accidental, by which an electric circuit or equipment is connected to the earth, or to some conducting body of large extent that serves in place of the earth. *Note:* It is used for establishing and maintaining the potential of the earth (or of the conducting body) or approximately that potential, on conductors connected to it, and for conducting ground current to and from the earth (or of the conducting body).²

hertz (Hz). A unit of frequency equal to one cycle per second.

IEEE. Institute of Electrical and Electronics Engineers.

Kelvin (K). The unit of temperature on the Kelvin Scale. It is one of the base units of SI. The word “degree” and its symbol (°) are omitted from this unit. See Temperature Scale for conversions.

Kelvin Scale. The Kelvin Thermodynamic Temperature Scale is the basis for all international scales, including the ITS-90. It is fixed at two points: the absolute zero of temperature (0 K), and the triple point of water (273.16 K), the equilibrium temperature that pure water reaches in the presence of ice and its own vapor.

line voltage. The RMS voltage of the primary power source to an instrument.

magnetic units. Units used in measuring magnetic quantities. Includes ampere-turn, gauss, gilbert, line of force, maxwell, oersted, and unit magnetic pole.



Dexing Magnet Tech. Co., Ltd

NBS. National Bureau of Standards. Now referred to as NIST.

National Institute of Standards and Technology (NIST). Government agency located in Gaithersburg, Maryland and Boulder, Colorado, that defines measurement standards in the United States. See Standards Laboratories for an international listing.

noise (electrical). Unwanted electrical signals that produce undesirable effects in circuits of control systems in which they occur.²

ohm (Ω). The SI unit of resistance (and of impedance). The ohm is the resistance of a conductor such that a constant current of one ampere in it produces a voltage of one volt between its ends.²

ppm. Parts per million, e.g., 4×10^{-6} is four parts per million.

precision. Careful measurement under controlled conditions which can be repeated with similar results. See repeatability. Also means that small differences can be detected and measured with confidence. See resolution.

prefixes. SI prefixes used throughout this manual are as follows:

<u>Factor</u>	<u>Prefix</u>	<u>Symbol</u>	<u>Factor</u>	<u>Prefix</u>	<u>Symbol</u>
10^{24}	yotta	Y	10^{-1}	deci	d
10^{21}	zetta	Z	10^{-2}	centi	c
10^{18}	exa	E	10^{-3}	milli	m
10^{15}	peta	P	10^{-6}	micro	μ
10^{12}	tera	T	10^{-9}	nano	n
10^9	giga	G	10^{-12}	pico	p
10^6	mega	M	10^{-15}	femto	f
10^3	kilo	k	10^{-18}	atto	a
10^2	hecto	h	10^{-21}	zepto	z
10^1	deka	da	10^{-24}	yocto	y

probe. A long, thin body containing a sensing element which can be inserted into a system in order to make measurements. Typically, the measurement is localized to the region near the tip of the probe.

repeatability. The closeness of agreement among repeated measurements of the same variable under the same conditions.²

resolution. The degree to which nearly equal values of a quantity can be discriminated.²

display resolution. The resolution of an instrument's physical display. This is not always the same as the measurement resolution of the instrument. Decimal display resolution specified as " n digits" has $10n$ possible display values. A resolution of n and one-half digits has $2 \times 10n$ possible values.

measurement resolution. The ability of an instrument to resolve a measured quantity. For digital instrumentation this is often defined by the analog to digital converter being used. A n -bit converter can resolve one part in 2^n . The smallest signal change that can be measured is the full scale input divided by 2^n for any given range. Resolution should not be confused with accuracy.

root mean square (RMS). The square root of the time average of the square of a quantity; for a periodic quantity the average is taken over one complete cycle. Also known as effective value.¹

RS-232C. Bi-directional computer serial interface standard defined by the Electronic Industries Association (EIA). The interface is single-ended and non-addressable.

semiconducting material. A conducting medium in which the conduction is by electrons, and holes, and whose temperature coefficient of resistivity is negative over some temperature range below the melting point.²

semiconductor. An electronic conductor, with resistivity in the range between metals and insulators, in which the electric charge carrier concentration increases with increasing temperature over some temperature range. Note: Certain semiconductors possess two types of carriers, namely, negative electrons and positive holes.²

setpoint. The value selected to be maintained by an automatic controller.¹

Add: No.300-402, Rd. West Jinshan, Huli Dist. Xiamen,China Zip code: 361015
 Tel: 86-592-5237772 Fax: 86-592-5237901
 Email: sales@magnetsource.com.cn



Dexing Magnet Tech. Co., Ltd

serial interface. A computer interface where information is transferred one bit at a time rather than one byte (character) at a time as in a parallel interface. RS-232C is a common serial interface.

stability. The ability of an instrument or sensor to maintain a constant output given a constant input.

tesla (T). The SI unit for magnetic flux density (B). 1 tesla = 104 gauss

tolerance. The range between allowable maximum and minimum values.

Underwriters Laboratories (UL). An independent laboratory that establishes standards for commercial and industrial products.

unit magnetic pole. A pole with a strength such that when it is placed 1 cm away from a like pole, the force between the two is 1 dyne.

volt (V). The difference of electric potential between two points of a conductor carrying a constant current of one ampere, when the power dissipated between these points is equal to one watt.²

volt-ampere (VA). The SI unit of apparent power. The volt-ampere is the apparent power at the points of entry of a singlephase, two-wire system when the product of the RMS value in amperes of the current by the RMS value in volts of the voltage is equal to one.²

watt (W). The SI unit of power. The watt is the power required to do work at the rate of 1 joule per second.²

Thank you for using DX-330 high-resolution high-precision Flux-gate Magnetometer

Dexing Magnet Tech.Co.,Ltd